

CARRELLI BIROTAIA IN TUBOLARE INOX 30x15x1,5

STAINLESS STEEL TUBULAR RUNNERS FOR TWIN RUNWAY 30x15x1,5

BIROTAIA

art. 207/3

CARRELLO BIROTAIA IN TUBOLARE INOX 30x15x1,5 SV. 210, RUOTE Ø90 IN NYLON 6 CON CUSCINETTI 15-42-13, RULLINI DI SCORRIMENTO Ø19x45 IN NYLON CON CAVALLOTTO A SNODO IN PIATTO INOX 30x5 CON GANCIO Ø15 A TESTA STAMPATA INOX AISI 420

STAINLESS STEEL TUBULAR RUNNER FOR TWIN RUNWAY 30x15x1,5 LENGTH 210, WHEELS Ø90 IN NYLON 6 WITH BEARINGS 15-42-13, ROLLERS Ø19x45 IN NYLON WITH ARTICULATED U-BOLT IN FLAT STAINLESS STEEL 30x5 WITH HOOK Ø15 DOME-HEADED AISI 420 STAINLESS STEEL

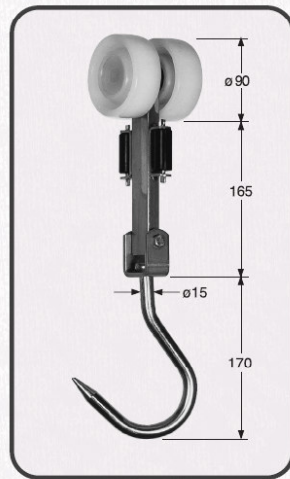

art. 207/12

CARRELLO BIROTAIA IN TUBOLARE INOX 30x15x1,5 SV. 170, RUOTE Ø60 IN NYLON 6 CON CUSCINETTI 15-35-11, RULLINI DI SCORRIMENTO Ø19x30 IN NYLON CON CAVALLOTTO A SNODO IN PIATTO INOX 30x5 CON GANCIO Ø12 INOX AISI 420

STAINLESS STEEL TUBULAR RUNNER FOR TWIN RUNWAY 30x15x1,5 LENGTH 170, WHEELS Ø60 IN NYLON 6 WITH BEARINGS 15-35-11, ROLLERS Ø19x30 IN NYLON WITH ARTICULATED U-BOLT IN FLAT STAINLESS STEEL 30x5 WITH Ø12 HOOK AISI 420 STAINLESS STEEL

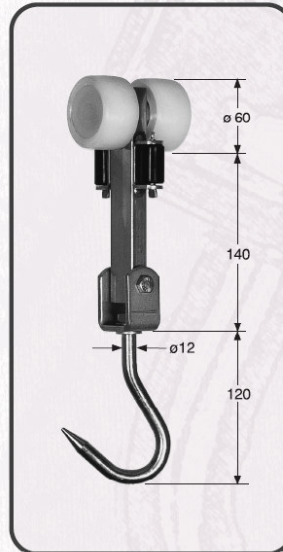

ANTIURTO
SHOCKPROOF
BUFFER

art. 207/23

CARRELLO BIROTAIA IN TUBOLARE INOX 30x15x1,5 SV. 210, CON RESPINGENTE ANTIURTO, RUOTE Ø90 IN NYLON 6 CON CUSCINETTI 15-42-13, RULLINI DI SCORRIMENTO Ø19x45 IN NYLON CON CAVALLOTTO A SNODO, IN PIATTO INOX 30x5 CON GANCIO GIREVOLE Ø15 INOX AISI 420

STAINLESS STEEL TUBULAR RUNNER FOR TWIN RUNWAY 30x15x1,5 LENGTH 210 WITH SHOCKPROOF BUFFER, WHEEL Ø90 IN NYLON 6 WITH BEARINGS 15-42-13, ROLLERS Ø19x45 IN NYLON WITH ARTICULATED U-BOLT IN FLAT STAINLESS STEEL 30x5 WITH Ø15 HOOK AISI 420 STAINLESS STEEL

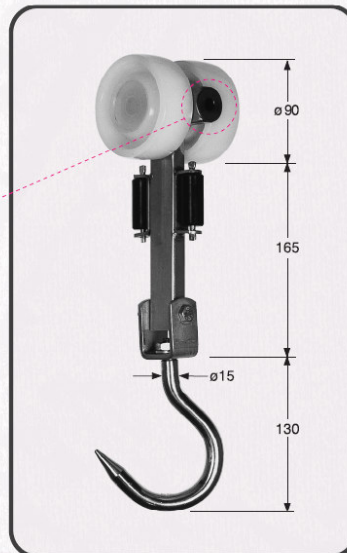

art. 207/32

CARRELLO BIROTAIA DOPPIO IN TUBOLARE INOX 30x15x1,5 SV.210, RUOTE Ø90 IN NYLON 6 CON CUSCINETTI 15-42-13, RULLINI DI SCORRIMENTO Ø19x30 IN NYLON CON TRAVERSINO PORTA-BILANCELLA IN LAMIERA INOX 40/10 INTERASSE 120mm.

DOUBLE STAINLESS STEEL TUBULAR RUNNER FOR TWIN RUNWAY 30x15x1,5 LENGTH 210, WHEELS Ø90 IN NYLON 6 WITH BEARINGS 15-42-13, ROLLERS Ø19x30 IN NYLON WITH CROSSPIECE FOR HANG RACK IN STAINLESS STEEL SHEET 40/10, CENTRE DISTANCE 120 mm.

BIROTAIA

**CARRELLI BIROTAIA IN FUSIONE ALLUMINIO
CAST ALUMINIUM RUNNERS FOR TWIN RUNWAY**

art. 208/2

CARRELLO BIROTAIA IN FUSIONE ALLUMINIO, RUOTE Ø90 IN NYLON 6 CON CUSCINETTI 15-42-13, RULLINI DI SCORRIMENTO Ø 19x45 IN NYLON CON CAVALLOTTO A SNODO, PIATTO 30x5 INOX CON GANCIO Ø15 A TESTA STAMPATA INOX AISI 420

CAST ALUMINIUM RUNNER FOR TWIN RUNWAY WHEEL Ø90 IN NYLON 6 WITH BEARINGS 15-42-13, ROLLERS Ø19x45 IN NYLON WITH ARTICULATED U-BOLT IN FLAT STAINLESS STEEL 30x5 WITH HOOK Ø15 DOME-HEADED AISI 420 STAINLESS STEEL

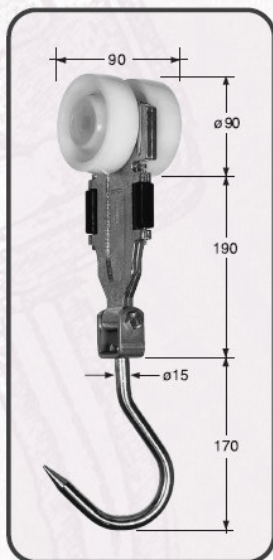

art. 208/24

CARRELLO BIROTAIA IN FUSIONE ALLUMINIO, RUOTE Ø60 IN NYLON 6 CON CUSCINETTI 15-35-11, RULLINI DI SCORRIMENTO Ø 17x45 IN NYLON CON CAVALLOTTO A SNODO, PIATTO 30x5 INOX CON GANCIO Ø15 A TESTA STAMPATA INOX AISI 420

CAST ALUMINIUM RUNNER FOR TWIN RUNWAY WHEELS Ø60 IN NYLON 6 WITH BEARINGS 15-35-11 ROLLERS Ø17x45 IN NYLON WITH ARTICULATED U-BOLT IN FLAT STAINLESS STEEL 30x5 WITH HOOK Ø15 DOME-HEADED AISI 420 STAINLESS STEEL

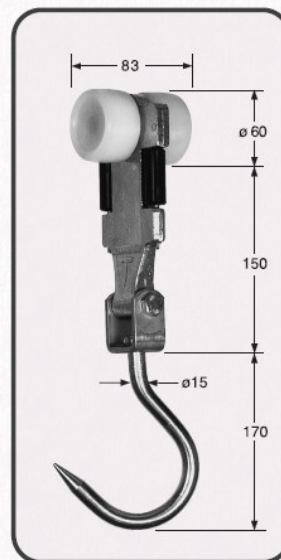

**CARRELLI BIROTAIA IN PIATTO
FLAT RUNNERS FOR TWIN RUNWAY**

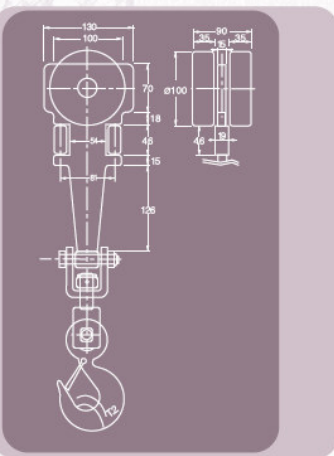
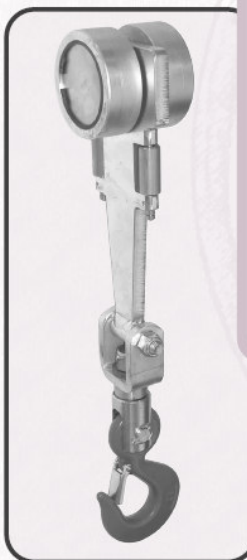

art. 210/11

CARRELLO BIROTAIA SAGOMATO AL LASER sp.15 mm IN FE ZINCATO PER LACCETTO BOVINO

PANTOGRAPHED RUNNER FOR TWIN RUNWAY IN FLAT GALVANIZED IRON 15 mm. FOR BEEF SHACKLE RUNNER

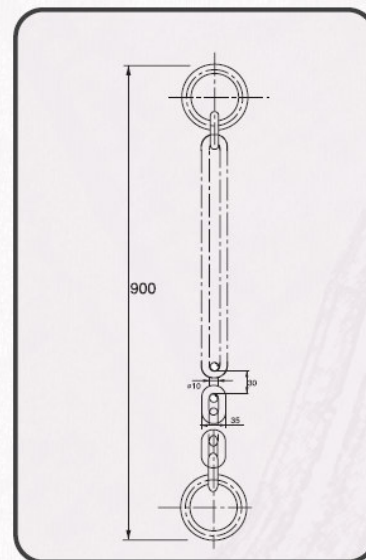

art. 210/12

CATENA PER LACCETTO BOVINO (CERTIFICATA) CON ANELLI ALL'ESTREMITA'

GALVANIZED BEEF SHACKLE CHAIN (CERTIFIED) WITH ONE RING ON ONE-END AND ONE RING TO THE OTHER

FLANGIA ANTIURTO
SHOCKPROOF FLANGE

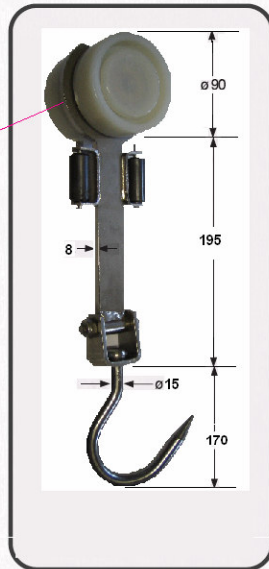

art. 210/43

CARRELLO BIROTAIA IN PIATTO INOX, SAGOMATO AL LASER, sp.8 mm., SAGOMA TONDA, RUOTE Ø90 IN NYLON 6 CON CUSCINETTI 15-42-13, RULLINI DI SCORRIMENTO Ø19x45 IN NYLON CON CAVALLOTTO A SNODO IN PIATTO 30x8, GANCIO Ø15 A TESTA STAMPATA INOX AISI 420

PANTOGRAPHED RUNNER FOR TWIN RUNWAY IN FLAT STAINLESS STEEL 8mm, THICK WITH ROUND SHAPE, WHEELS Ø90 IN NYLON 6 BEARINGS 15-42-13, ROLLERS Ø19x45 IN NYLON ARTICULATED U-BOLT IN FLAT STAINLESS STEEL 30x8, HOOK Ø15 DOME-HEADED AISI 420 STAINLESS STEEL

FLANGIA ANTIURTO
SHOCKPROOF FLANGE

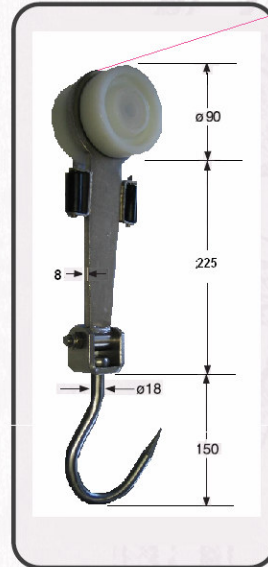

art. 210/21

CARRELLO BIROTAIA IN PIATTO INOX, SAGOMATO AL LASER, sp.8 mm., SAGOMA TONDA, RUOTE Ø90 IN NYLON 6 CON CUSCINETTI 15-42-13, RULLINI DI SCORRIMENTO Ø19x45 IN NYLON CON CAVALLOTTO A SNODO IN PIATTO 30x8, GANCIO Ø18 A TESTA STAMPATA INOX AISI 420

PANTOGRAPHED RUNNER FOR TWIN RUNWAY IN FLAT STAINLESS STEEL 8 mm, THICK WITH ROUND SHAPE, WHEELS Ø90 IN NYLON 6 BEARINGS 15-42-13, ROLLERS Ø19x45 IN NYLON ARTICULATED U-BOLT IN FLAT STAINLESS STEEL 30x8, HOOK Ø18 DOME-HEADED AISI 420 STAINLESS STEEL

FLANGIA ANTIURTO
SHOCKPROOF FLANGE

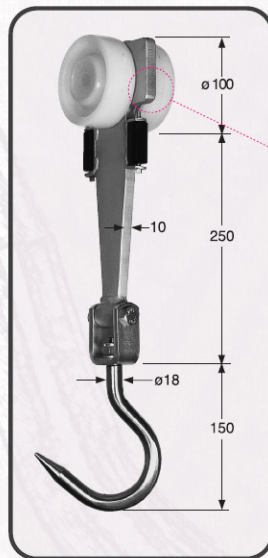

art. 210/1

CARRELLO BIROTAIA SAGOMATO AL LASER sp.10 mm. IN FERRO ZINCATO, RUOTE Ø100 IN NYLON 6, RULLINI DI SCORRIMENTO Ø19x45 IN NYLON CON CAVALLOTTO A CATENA PER LACCETTO BOVINO (CERTIFICATA).

PANTOGRAPHED RUNNER FOR TWIN RUNWAY GALVANIZED IRON 10 mm. THICK, WHEELS Ø100 IN NYLON 6, ROLLERS Ø19x45 IN NYLON WITH CHAIN (CERTIFIED) FOR BEEF SHACKLE RUNNER

ATTACCO PER PARANCO
TACKLE ATTACHMENT

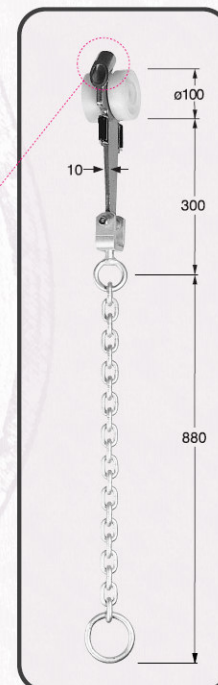

art. 210/50

CARRELLO BIROTAIA SAGOMATO AL LASER sp.10 mm IN FERRO ZINCATO, RUOTE Ø100 IN NYLON 6, RULLINI DI SCORRIMENTO Ø19x45 IN NYLON CON CAVALLOTTO A SNODO, IN PIATTO 30x8, GANCIO Ø18 INOX AISI 420

PANTOGRAPHED RUNNER FOR TWIN RUNWAY GALVANIZED IRON 10 mm THICK, WHEELS Ø100 IN NYLON 6, ROLLERS Ø19x45 IN NYLON ARTICULATED U-BOLT IN FLAT IRON 30x8, HOOK Ø18 AISI 420 STAINLESS STEEL

BIROTAIA

SCAMBI DIREZIONALI PER GUIDOVIA BIROTAIA IN TUBOLARE INOX 60X40X2 E RELATIVI ACCESSORI

STAINLESS STEEL SWITCH AND RELATIVE ACCESSORIES FOR TWIN RUNWAY 60X40X2

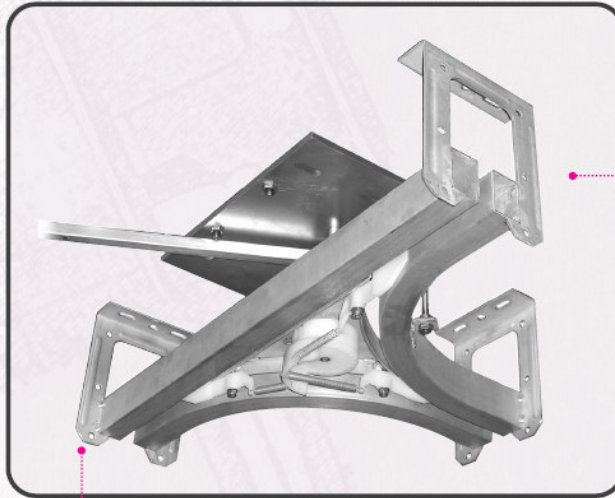

**art. 520
art. 520/1**

**SCAMBIO BIROTAIA A 3 VIE
3-WAY SWITCH**

**art. 520
SCAMBIO BIROTAIA A 3 VIE
- RAGGIO 400 -
3-WAY SWITCH
- RADIUS 400 -**

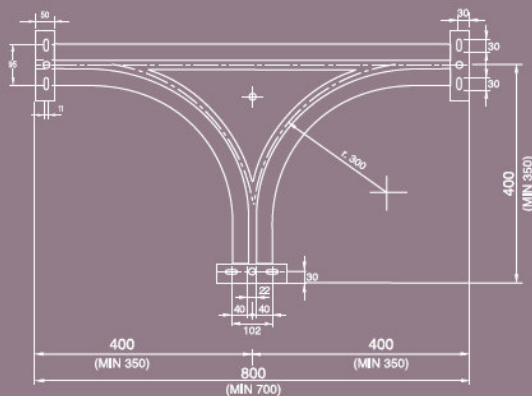
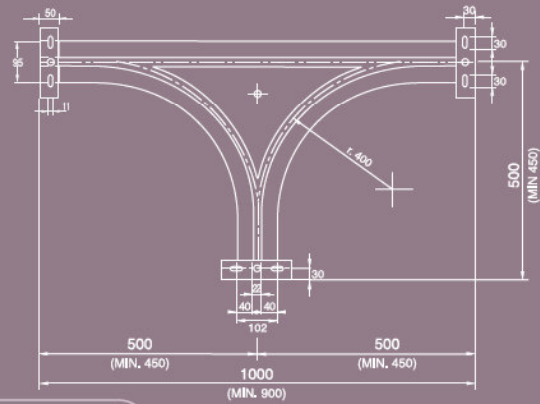

**art.520/1
SCAMBIO BIROTAIA A 3 VIE
- RAGGIO 300 -
3-WAY SWITCH
- RADIUS 300 -**

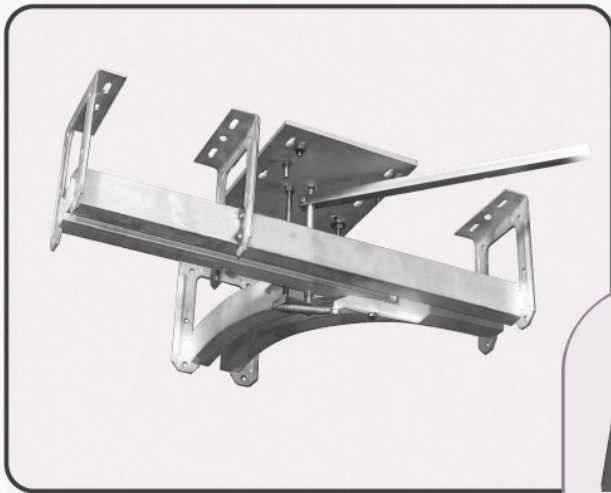

art. 521

SCAMBIO A DUE VIE A 90°
90° 2-WAY SWITCH

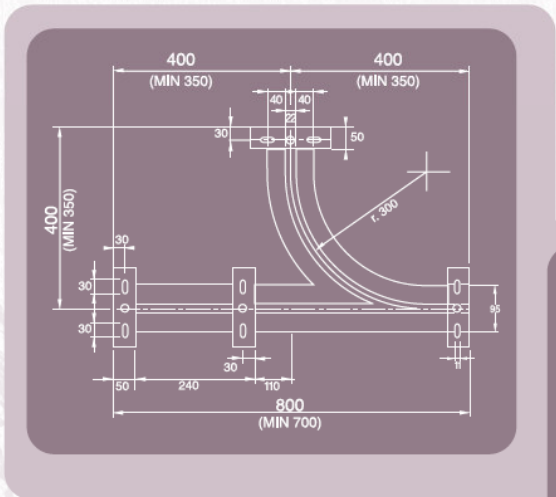
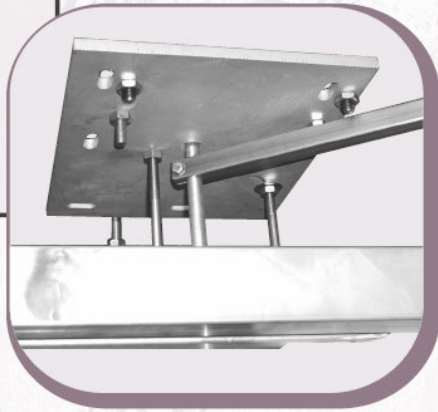

art.521/2

SCAMBIO A 2 VIE 90° - RAGGIO 300 - DX
90° 2 WAY SWITCH - RADIUS 300 - RIGH

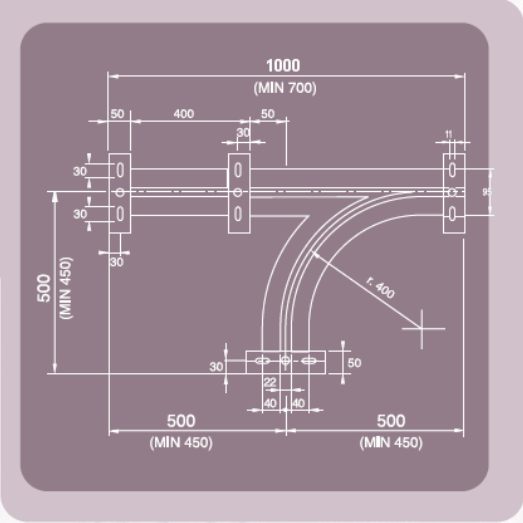

art.521/1

SCAMBIO A 2 VIE 90° - RAGGIO 400 - SX
90° 2 WAY SWITCH - RADIUS 400 - LEFT

art. 522

CURVA PER BIROTAIA INOX A 90°

90° BEND FOR STAINLESS STEEL TWIN RUNWAY

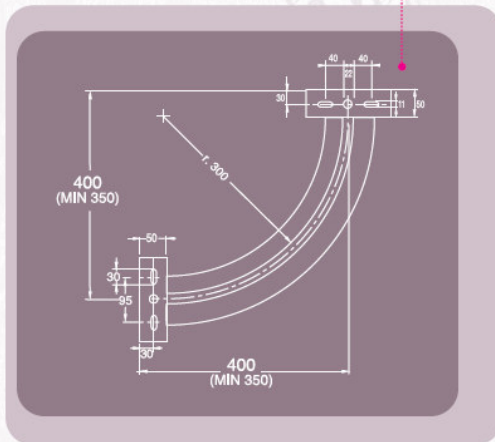
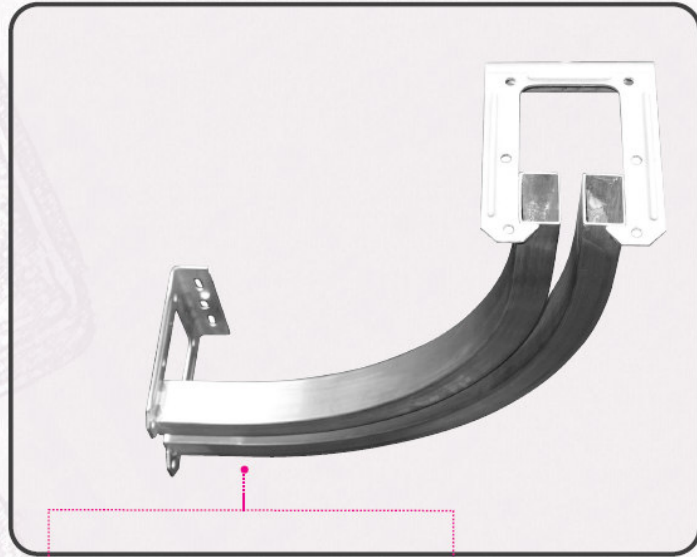

art. 522/1

CURVA INOX A 90° - RAGGIO 300 -

90° BEND FOR STAINLESS STEEL -
RADIUS 300 -

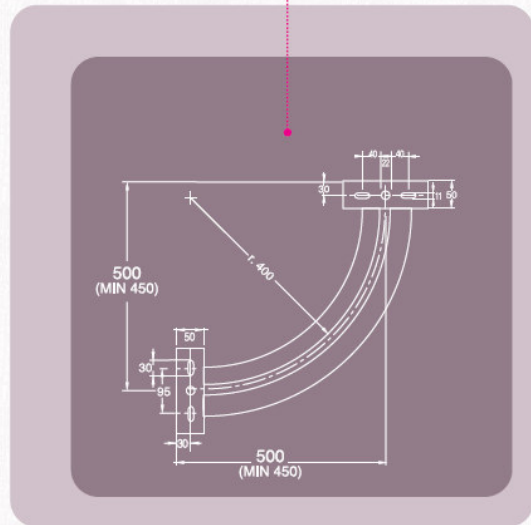

art. 522/3

CURVA INOX A 90° - RAGGIO 400 -

90° BEND FOR STAINLESS STEEL - RADIUS 400 -

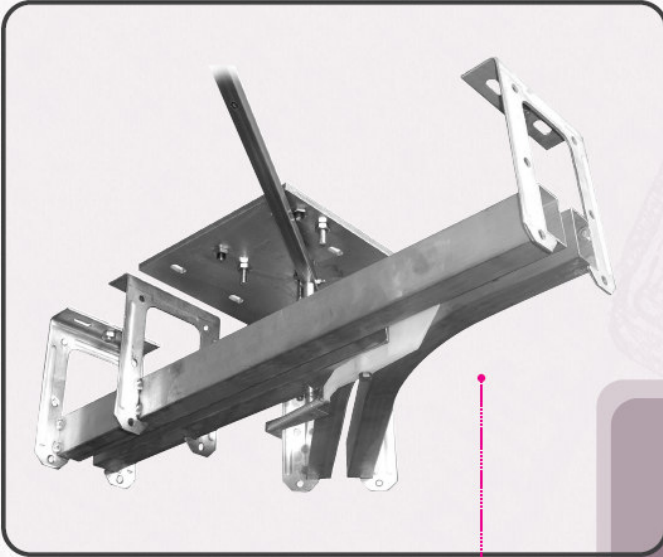

art. 521/4

SCAMBIO A DUE VIE A 45°

45° 2-WAY SWITCH

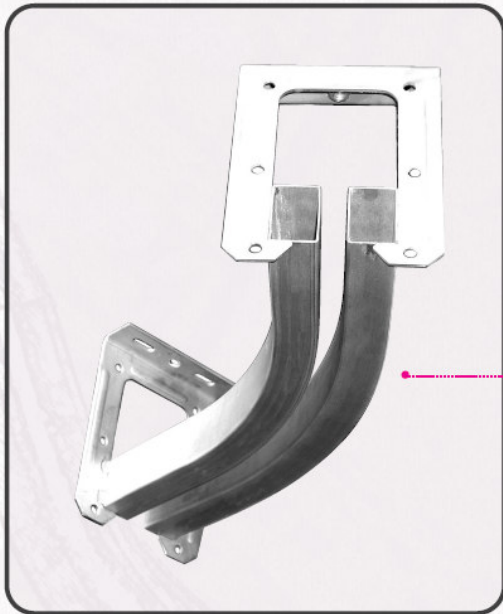
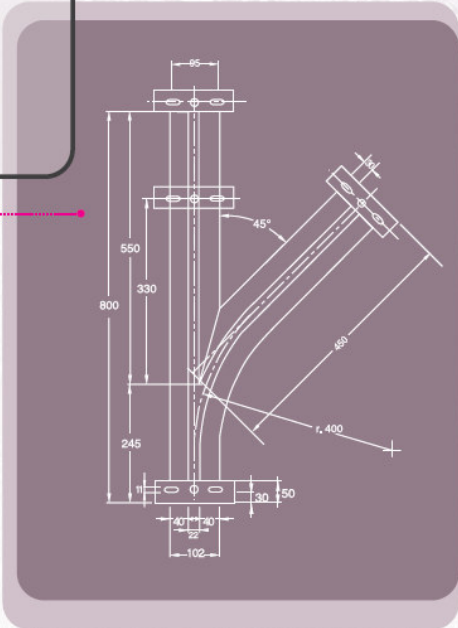
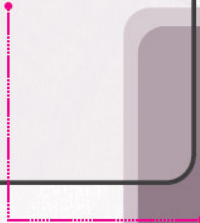

art. 522/4

CURVA PER BIROTAIA INOX 45°

45° BEND FOR STAINLESS STEEL TWIN RUNWAY

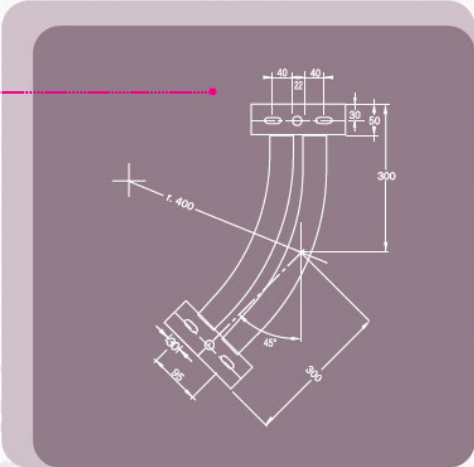

MONOROTAIA

SCAMBIO BIROTAIA ROTATIVO MOTORIZZATO

POWERED ROTATIVE SWITCH

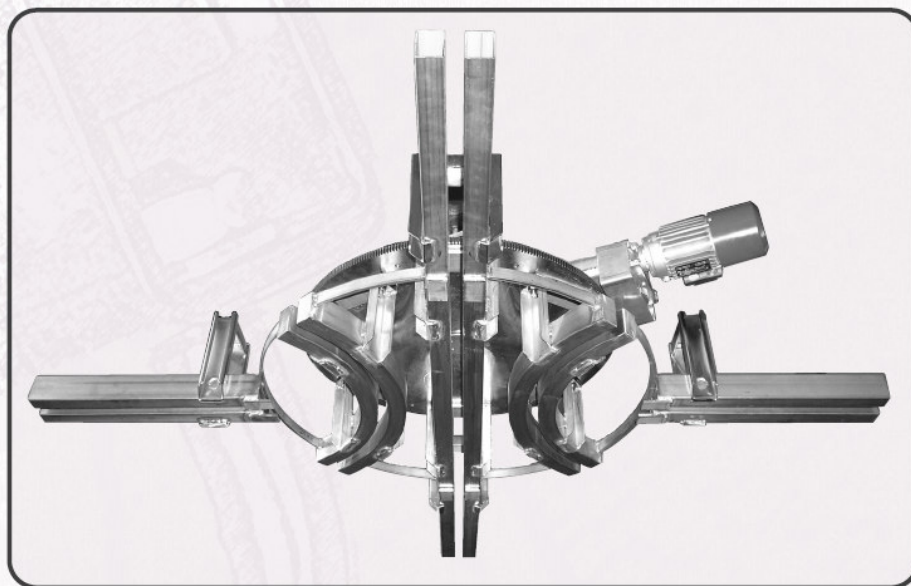

art. 519

SCAMBIO BIROTAIA ROTATIVO MOTORIZZATO CON PIASTRE IN FERRO NICHELATO E BIROTAIA IN ACCIAIO INOX COMPLETO DI QUADRO ELETTRICO E FINE CORSA.

POWERED ROTATIVE SWITCH WITH IRON NICKELLED PLATE AND STAINLESS STEEL TWIN RUNWAY COMPLETE OF ELECTRICAL PANEL AND END RACE.

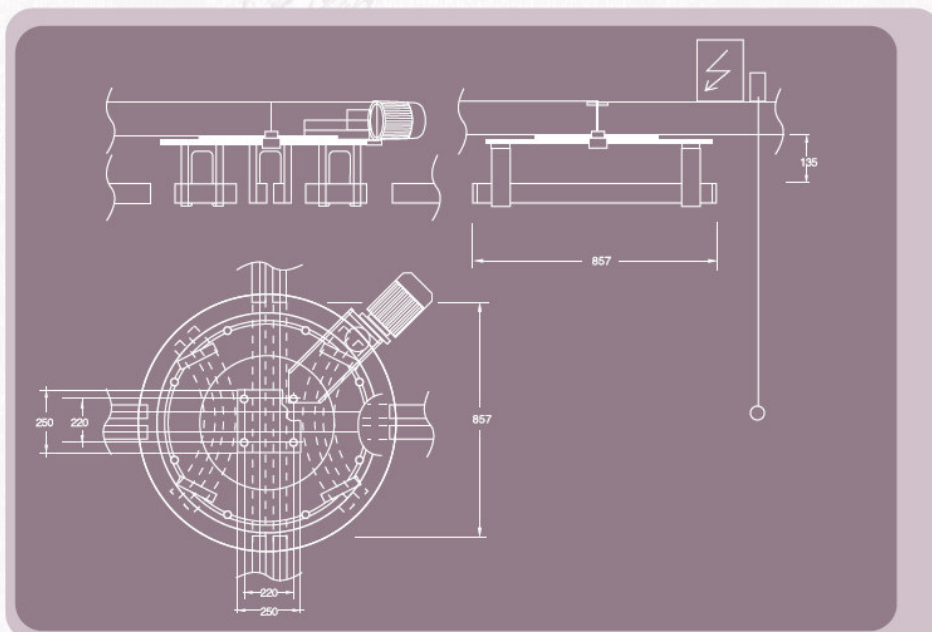

TESTATE COMPOSTE DA SCAMBI BIROTAIA A 3 VIE, 2 VIE, CURVE SU DISEGNO

THE HEADS CONSISTS OF THE FOLLOWING PARTS: 3-WAY SWITCH , 2-WAY SWITCH , BEND ABOUT DRAWING

MONOROTAIA

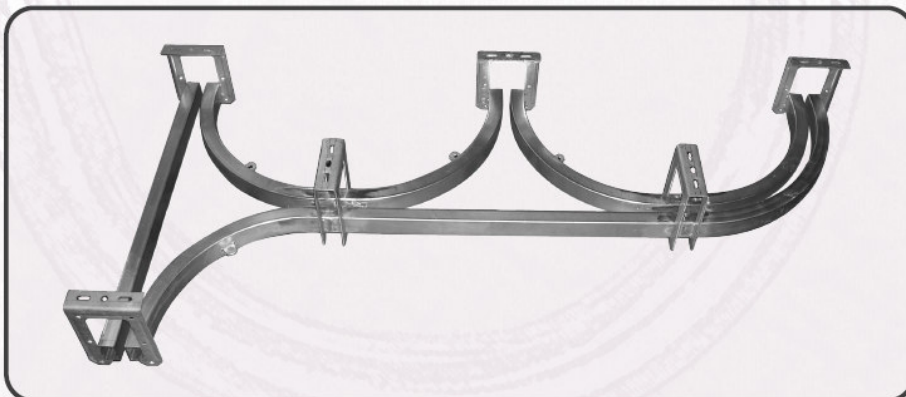
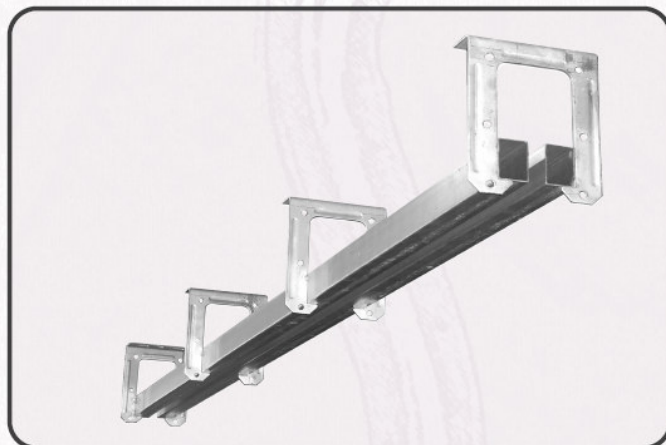
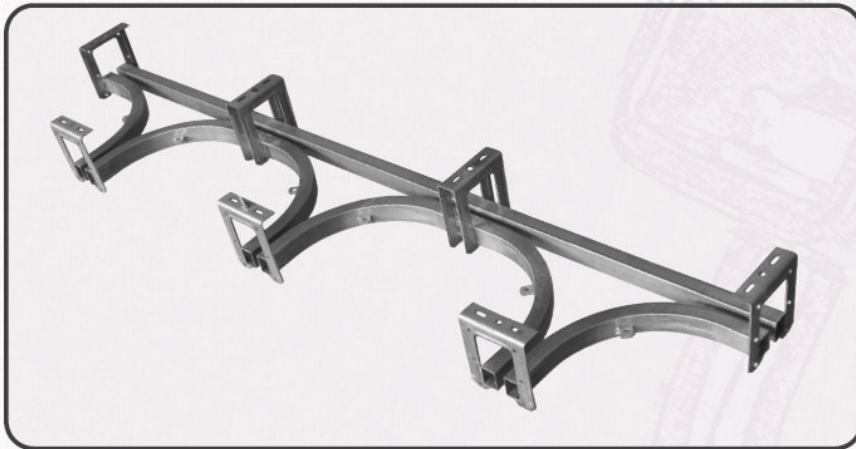

BIROTAIA

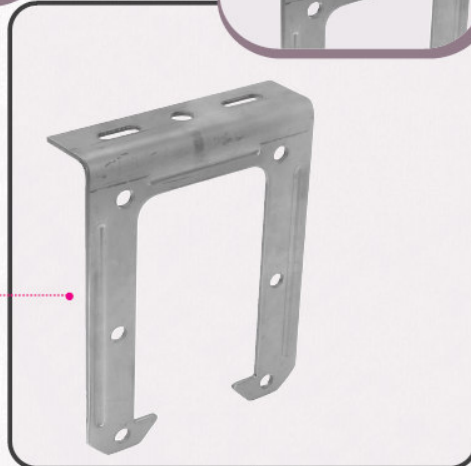
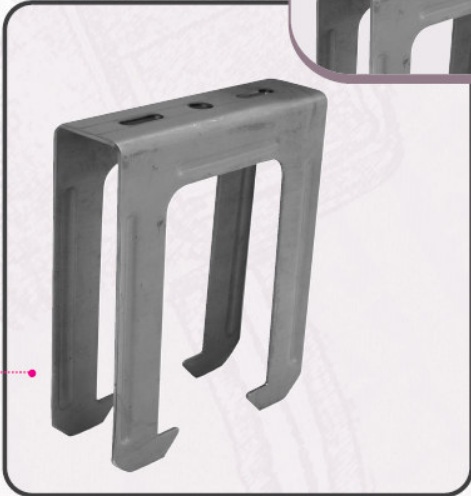

art.523

GRAFFA DOPPIA PER BIROTAIA INOX COMPLETA DI GRAFFINI

DOUBLE FASTENER FOR STAINLESS STEEL TWIN RUNWAY COMPLETE WITH SMALL FASTENERS

art.524

GRAFFA SEMPLICE PER BIROTAIA INOX COMPLETA DI GRAFFINI

SIMPLE FASTENER FOR STAINLESS STEEL TWIN RUNWAY COMPLETE WITH SMALL FASTENERS

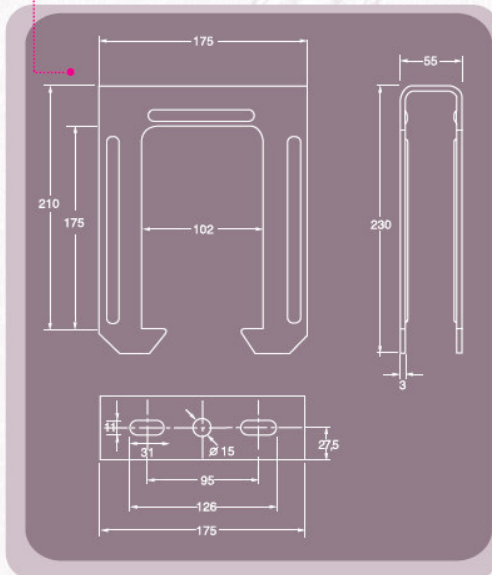

QUOTE GRAFFA DOPPIA
DOUBLE FASTENER VALUES

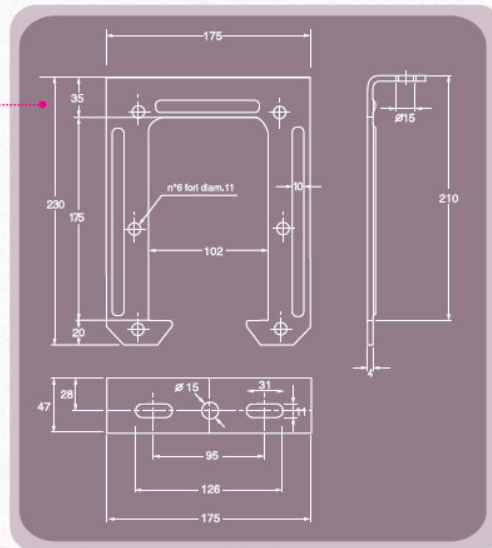

QUOTE GRAFFA SEMPLICE
SIMPLE FASTENER VALUES